

# INVER SOL



## TRANSPAK

TRANSPAK EQUIPMENT CORP.



### SELLADOR PARA ZUNCHO PLASTICO

## MODELO H-35

- HECHO DE MATERIAL PROCESADO A ALTAS TEMPERATURAS PARA ASEGURAR EL MÁXIMO RENDIMIENTO.
- FUNCIONA CON LA TENSIONADORA H-21.

### DATOS TÉCNICOS

<b>CÓDIGO</b>	H-35-16
<b>CARACTERÍSTICAS</b>	AGARRE DE TRIPLE FRICCIÓN LONGITUD DE MANGO: 390MM
<b>PRESENTACIÓN</b>	CAJA DE CARTÓN

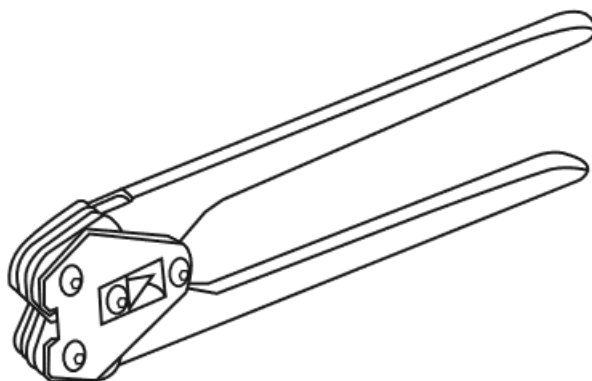

Importadora y Comercializadora Hassi Spa  
Las Dalias 2900 Macul Santiago  
Fono: 22 963 89 30  
[www.inversol.cl](http://www.inversol.cl)  
Email: [Ventas@inversol.cl](mailto:Ventas@inversol.cl)